

Conserve water • Increase yields • Reduce nutrient loss

Enjoy the agricultural and environmental benefits of **VARIABLE RATE DRAINAGE**®.

The Water Gate is a float-activated head pressure valve. It maintains a 6" increase in water elevation between the downstream and upstream sides of the valve.

8", 10", & 12" Water Gates with 6" Lift

- ◆ Manage up to 12"-diameter subsurface drain tile.
- ◆ Fully automatic.
- ◆ Float operated.
- ◆ Infinitely variable.
- ◆ Completely buried to allow for convenient field operations.
- ◆ Installation using flexible couplers on the upstream and downstream sides is recommended.
- ◆ Valves are not pressure rated.
- ◆ Valves are intended for gravity flow:
Low pressure and some seepage may occur.*

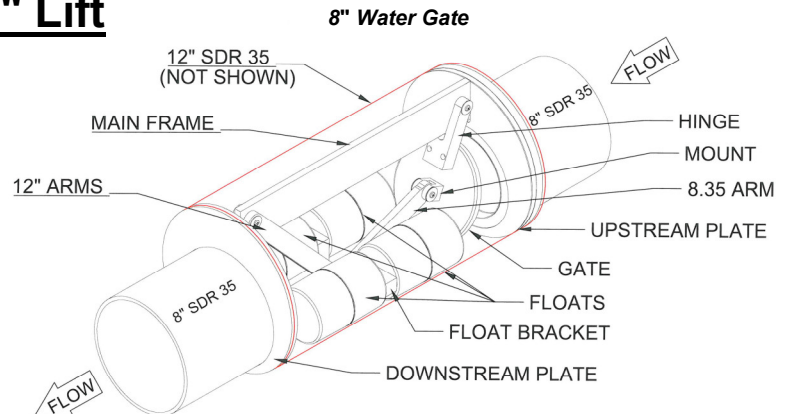

*To minimize seepage, we recommend installing 20' of non-perforated pipe on the upstream side of the Water Gate, or using an Anti-Seep Collar below the Water Gate.

Installation Instructions: The Water Gate operates in either free-flow or managed-flow mode. The managed-flow mode is activated by backing water up into the valve. This is accomplished by installing a Water Level Control Structure (WLCS) in the tile main at the lowest point of the drainage system that you wish to manipulate or control.

After installing the Water Level Control Structure, check the elevation of the inside bottom of the structure and then locate the point at which flow line of the tile is 6" higher in elevation. This is where the first Water Gate will be installed. When installing a series of Water Gates, continue to locate them at 6" elevation intervals.

Be certain that the flow direction label is aligned with the direction of flow. Install the Water Gate with bubble level facing up and bubble centered. If you over excavate, the use of gravel under the Water Gate will ensure proper installation and prevent settling. Backfill around the Water Gate by hand: hand tamp only—do not mechanically compact. Do not use a backhoe or blade to place backfill directly against the Water Gate. A minimum of 30" of cover is required in traffic areas.

To increase the height of the water table throughout your drainage system, simply add stoplogs to the WLCS. The minimum stop log elevation at the WLCS must be 18" to obtain 6" of lift at the Water Gate Valve. Add additional stoplogs to raise upstream water throughout the system.

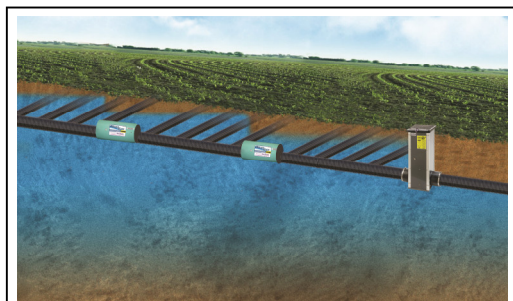

Side view of how Inline Water Level Control Structure™ and Water Gates "stair-step" water up through the soil profile.

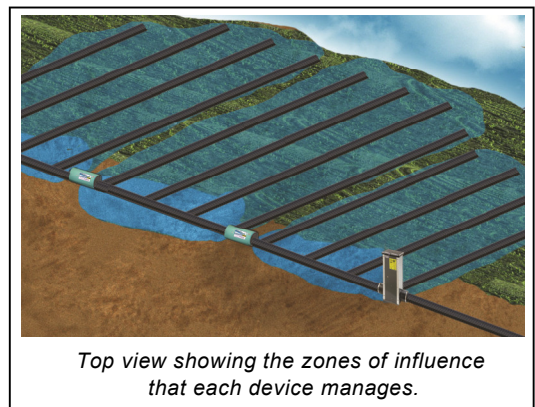

Top view showing the zones of influence that each device manages.